

Effects of Cold Plasma on Staphylococcus Aureus

Abolfazl Mazandarani; Ph.D.¹, Shervin Goudarzi; Ph.D.¹, Mina Jafarabadi; M.D.²,
Elham Azimi Nekoo; M.D.³

1 Plasma and Nuclear Fusion Research School, Nuclear Science and Technology Research Institute, Atomic Energy Organization, Tehran, Iran

2 Vali-E-Asr Reproductive Health Research Center, Family Health Research Institute, Tehran University of Medical Sciences, Tehran, Iran

3 Jacobi Medical Center / Albert Einstein University, New York, United States

Received July 2022; Revised and accepted July 2022

Abstract

Objective: To investigate the effect of cold plasma on Staphylococcus aureus destruction at different treatment times.

Materials and methods: Staphylococcus aureus was cultured on 4 plates of LB Agar medium each at 1.5×10^3 CFU / mL (colony-forming unit per milliliter) and one group was selected as the control group and the other 3 groups were treated with plasma for 5, 7 and 10 minutes. They were incubated for 24 hours at 37 °C. Finally, the number of colonies formed was counted.

Results: It was shown that treatment with cold atmospheric plasma significantly reduced bacterial colonies and in comparison to the control plate with a colony count of 1.5×10^3 CFU/mL treatment with air plasma for 10 minutes decreased the Pseudomonas colony count to zero.

Conclusion: It was observed that the cold atmospheric plasma jet device manufactured in atomic Energy Organization of Iran can significantly kill bacteria in a short time. Increasing the duration of treatment significantly reduces bacterial colonies.

Keywords: Cold Atmospheric Plasma; Staphylococcus Aureus; Bacterial Destruction

Introduction

Staphylococcus aureus is one of the most widespread pathogenic bacteria. This bacterium is found on the mucous membranes and skin of mammals, various foods and the environment and causes pneumonia after viral infections, urinary tract infections, inflammation of the veins and superficial skin lesions, etc. (1, 2).

One of the most important groups of toxins produced by Staphylococcus aureus are enterotoxins, which are

divided into types A to V. These toxins are similar in structure and biological activity, but their antigenic properties are different. More than 95% of these enterotoxins cause food poisoning in human (3-5).

Staphylococcus aureus is a gram-positive and coagulase positive cocci of the Staphylococcus family and an opportunistic infection agent in humans. This bacterium is of great importance due to the increase in antibiotic resistance and in addition is one of the most important and abundant causes of nosocomial infections worldwide. Staphylococcus aureus is present as a human pathogen in 30% of the population and is one of the important causes of

Correspondence:

Dr. Shervin Goudarzi

Email: sgoudarzi@aepi.org.ir



Copyright © 2022 Tehran University of Medical Sciences. Published by Tehran University of Medical Sciences.

This work is licensed under a Creative Commons Attribution-NonCommercial 4.0 International license (<https://creativecommons.org/licenses/by-nc/4.0/>).

Noncommercial uses of the work are permitted, provided the original work is properly cited.

severe and deadly diseases. The clinical manifestations of Staphylococcus aureus are highly variable. Infections associated with this bacterium include: bacteremia, sepsis, pneumonia, osteomyelitis, and skin infections in humans. The spread of methicillin-resistant staphylococcus aureus (MRSA) strains has now become one of the main therapeutic challenges.

This strain is one of the leading causes of skin and tissue infections in the United States and is primarily responsible for postoperative infections that produce toxins and are sometimes associated with shock. The persistent emergence of multidrug-resistant bacteria in many health care institutions has challenged the effectiveness of clinical antibiotics, most notably beta-lactam antibiotics such as penicillin, methicillin, oxacillin, nafcillin, and cephalosporins (6, 7).

For several decades, the fourth state of matter, plasma, has been stated to be valuable in different fields of science and applications. Cold Atmospheric Pressure Plasma technology has made very dynamic advances in the biological sciences in the last decade, especially in medicine, food industry and agriculture. Recently researches are published on the use of plasma to kill bacteria showing plasma may have a positive effect on the destruction of bacteria and microbes as an effective method. In this paper, the effect of cold plasma on Staphylococcus aureus was investigated via the performance of cold plasma at different times of treatment. This research has been done in Nuclear Science and Technology Research Institute, Atomic Energy Organization of Iran (8).

Materials and methods

The cold plasma jet device used in this study (Figures 1 and 2) uses ambient air. This device has 2 parts: Power supply section and plasma generator jet nozzle section. Electrons, ions, hydroxyl radicals, oxygen atoms, ozone and hydrogen peroxide are the major products produced at the nozzle output. Atmospheric cold plasma devices usually consume low power (9).

This device uses a voltage boost transformer that applies a voltage of 2.6 kV to the nozzle. The nozzle consists of a cylindrical rod of aluminum as the outer electrode, and a small-diameter rod as the inner electrode. A cylindrical quartz dielectric is also located between the inner and outer electrodes of the electrode. The air flow to the nozzle is reached by a pump with a flow rate of 3 liters per minute. The length of the plasma jet formed in the nozzle under these conditions is equal to 4 mm. The length of the plasma jet decreases as the airflow of the pump decreases, the amplitude and width of the voltage pulse decrease.

Bacterial samples used in the present study were extracted from clinical cases. Studied samples were cultured in LB Broth medium and kept in an incubator for 24 hours at 37 °C. A second sample was prepared from the first 24 hours culture and was re-cultured. After 24 hours the colonies of microorganisms from each plate were processed. Some of the colonies were inoculated in sterile PBS buffer and were added in different amounts to the cuvette tubes. Using a spectrophotometer their light absorption during a wave of 600 nm was determined and the number of bacteria was calculated.

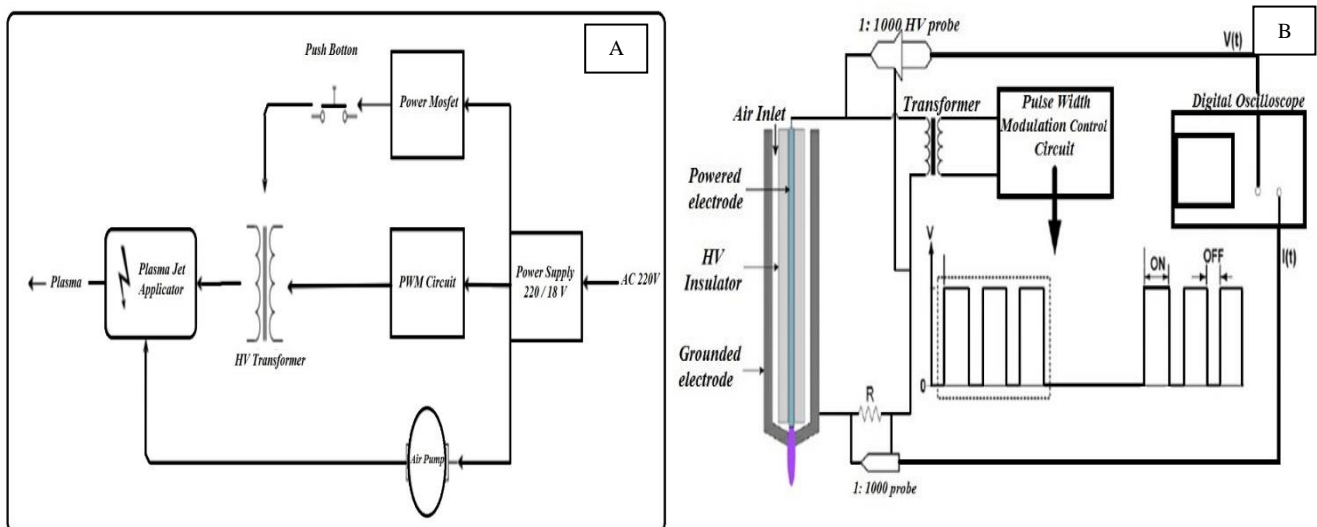

Figure 1: The cold plasma jet device. A) Circuitry. B) Structure

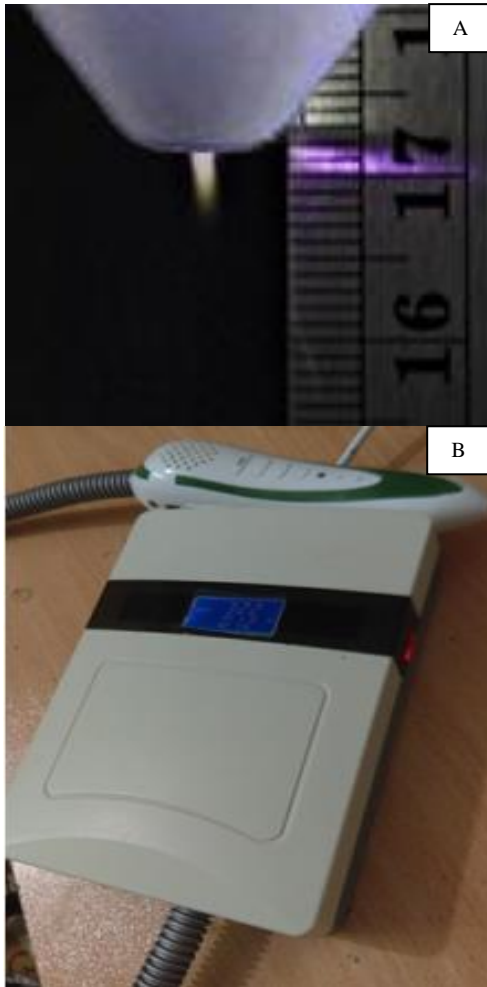

Figure 2: Jet plasma; A) jet plasma's length. B) Jet plasma device

After determining the number of *Staphylococcus aureus* bacteria inoculated in PBS, a certain amount of bacteria was transferred to a designated medium from the plate surface containing LB Agar culture medium. The bacteria were allowed to sit on the medium for 2 minutes. The medium containing the bacteria was treated with atmospheric cold plasma. Plasma treatment of bacteria has been investigated at different time durations.

The treatment times were exactly 5, 7 and 10 minutes; for each group of bacteria with variable treatment times, a control plate (without plasma treatment) was determined to compare the effect. After treating the plates, they were kept in an incubator for 24 hours at 37 °C, after which, the final colonies were counted.

Staphylococcus aureus was cultured on 4 plates of LB Agar medium each at 1.5×10^3 CFU / mL and one group was selected as the control group and the

other 3 groups were treated with plasma for 5, 7 and 10 minutes. They were placed in a cold atmosphere, then the plates were incubated for 24 hours at 37 °C, and then the number of colonies formed was counted (Figures 3 to 7).



Figure 3: Plate of the control group

Results

In these experiments, *Staphylococcus aureus* was cultured on 4 plates.

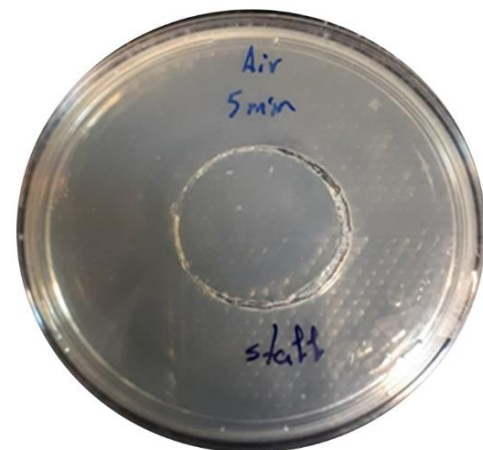

Figure 4: Plate of the group treated with cold plasma for 5 minutes

Three groups were treated with Cold atmospheric plasma for 5, 7 and 10 minutes and the 4th group was selected as the control group. Then the plates were incubated for 24 hours at 37 °C, and then the number of colonies formed was counted (Figures 3 to 7).

Counting *Staphylococcus aureus* colonies under the influence of cold atmospheric plasma was done to evaluate the power of the device.



Figure 5: Plate of the group treated with cold plasma for 7 minutes

The results of final colony counts are summarized in table 1. As shown in figure 8 increasing the duration of treatment significantly reduces bacterial colonies.

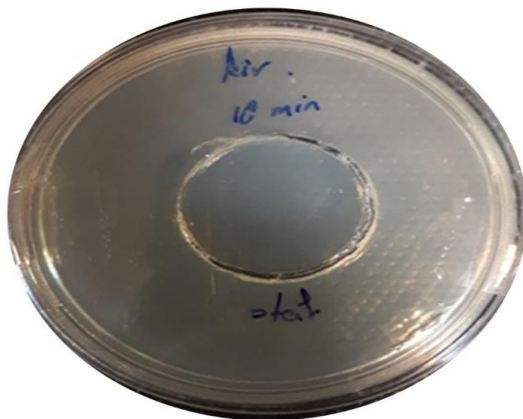

Figure 6: Plate of the group treated with cold plasma for 10 minutes

Discussion

The attractiveness of atmospheric plasmas and other low-temperature plasma sources for therapeutic applications will greatly increase in the coming years.

Table 1: Final colony counts after treatment with cold atmospheric plasma in different time durations

Plate	Colony count
Control Staphylococcus air	1.5×10^3 CFU/mL
5 min air plasma Pseudomonas	0.09×10^3 CFU/mL
7 min air plasma Pseudomonas	0.05×10^3 CFU/mL
10 min air plasma Pseudomonas	0

These sources are non-thermal and therefore, can be applied to living tissue without heat damage and therefore there is no risk of irreparable damage due to denaturation of proteins in these sources. The use of plasma produces special structures such as reactive oxygen species and nitrogen species (RONS) that lead to antibacterial effects. In recent years, several reports have been published on the effectiveness of plasma sources against antibiotic-resistant bacteria as well as against biofilms produced by these bacteria. In addition, there have been no reports of bacterial resistance in plasma therapy. Various researchers have investigated the effect of atmospheric cold pressure plasma on drug-resistant bacteria such as MRSA in suspended, adhered to surfaces or placed in biofilms (10-12).

Some of these studies showed differences in the susceptibility of MRSA (Methicillin-resistant Staphylococcus aureus) and MSSA (methicillin-susceptible Staphylococcus aureus) strains to plasma therapy for planktonic or suspended form after biofilm culture. It was found that using 2 minutes of atmospheric plasma reduces bacterial survival by 6 to 10%.

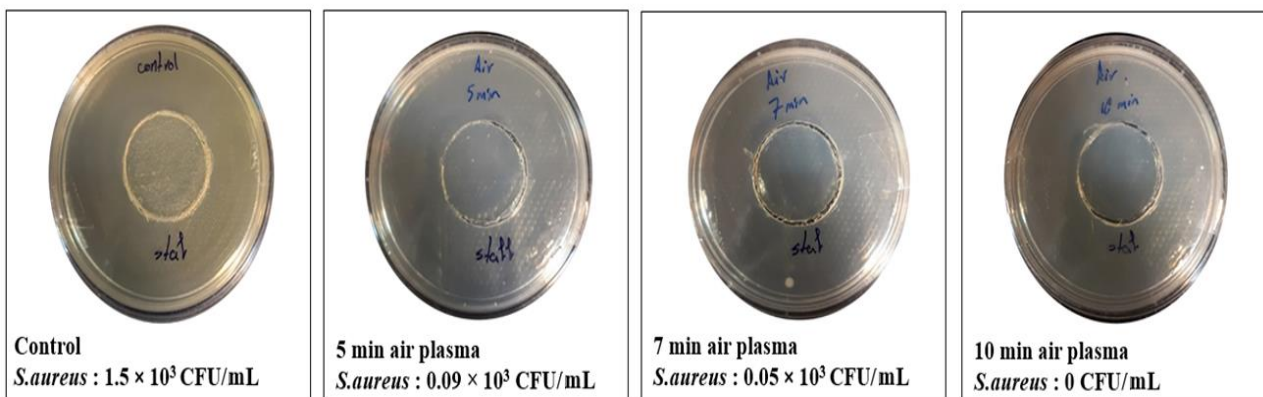

Figure 7: Overview of all groups treated with air plasma and Staphylococcus aureus control group

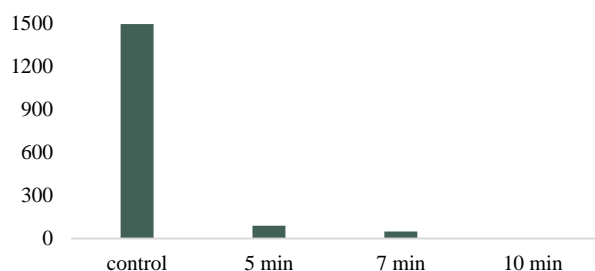

Figure 8: The effect of long-term plasma treatment on the amount of *Staphylococcus aureus*

As mentioned, increasing the resistance of bacteria to antibiotics is one of the major challenges facing scientists in the world, and that is why the use of new methods has received so much attention. The use of plasma has become very common today and it may be possible to find a solution to the problem of bacterial resistance to antibiotics. The results of our experiments showed that in vitro the device was able to kill most of the bacteria in the culture medium within 7 and 10 minutes.

The antibacterial mechanism of atmospheric cold plasma can be due to the role of ROS and RNS free radicals in the bacterial environment. In fact, cold atmospheric plasma by creating ROS free radicals with a direct effect on membrane lipids, especially phospholipids, destroys the structure and integrity of bacterial membranes and also damages bacterial DNA, which results in complete destruction and destruction of bacteria.

In fact, free radicals are molecules and atoms that, due to having free electrons, contain high energy and are able to damage tissues and cells, given that prokaryotes have a strong anti-inflammatory and anti-inflammatory system. Do not have free radicals, so this path can be used to damage bacteria.

Conclusion

It was observed that the cold atmospheric plasma jet device manufactured in atomic Energy Organization of Iran can significantly kill bacteria in a short time. Increasing the duration of treatment significantly reduces bacterial colonies.

Acknowledgments

Authors have no conflict of interests.

References

1. Kluytmans J, van Belkum A, Verbrugh H. Nasal

carriage of *Staphylococcus aureus*: epidemiology, underlying mechanisms, and associated risks. *Clin Microbiol Rev.* 1997; 10:505-20.

2. Dinges MM, Orwin PM, Schlievert PM. Exotoxins of *Staphylococcus aureus*. *Clin Microbiol Rev.* 2000; 13:16-34, table of contents.

3. Balaban N, Rasooly A. Staphylococcal enterotoxins. *Int J Food Microbiol.* 2000; 61:1-10.

4. Ertas N, Gonulalan Z, Yildirim Y, Kum E. Detection of *Staphylococcus aureus* enterotoxins in sheep cheese and dairy desserts by multiplex PCR technique. *Int J Food Microbiol.* 2010; 142:74-7.

5. Akineden O, Hassan AA, Schneider E, Usleber E. Enterotoxigenic properties of *Staphylococcus aureus* isolated from goats' milk cheese. *Int J Food Microbiol.* 2008; 124:211-6.

6. Harris LG, Foster SJ, Richards RG. An introduction to *Staphylococcus aureus*, and techniques for identifying and quantifying *S. aureus* adhesins in relation to adhesion to biomaterials: review. *Eur Cell Mater.* 2002; 4:39-60.

7. Morell EA, Balkin DM. Methicillin-resistant *Staphylococcus aureus*: a pervasive pathogen highlights the need for new antimicrobial development. *Yale J Biol Med.* 2010; 83:223-33.

8. Mazadarani A. Design and manufacture of DBD plasma generator suitable for use in agriculture. Ph.D. Thesis, Nuclear Science and Technology Research Institute, December 2020.

9. Sambrook JF, Russell DW. *Molecular cloning: A laboratory manual.* 4th ed. New York: Cold spring harbor laboratory press, 2001.

10. Bourke P, Ziuzina D, Han L, Cullen PJ, Gilmore BF. Microbiological interactions with cold plasma. *J Appl Microbiol.* 2017; 123:308-324.

11. Burts ML, Alexeff I, Meek ET, McCullers JA. Use of atmospheric non-thermal plasma as a disinfectant for objects contaminated with methicillin-resistant *Staphylococcus aureus*. *Am J Infect Control.* 2009; 37:729-33.

12. Ermolaeva SA, Varfolomeev AF, Chernukha MY, Yurov DS, Vasiliev MM, Kaminskaya AA, Moisenovich MM, et al. Bactericidal effects of non-thermal argon plasma in vitro, in biofilms and in the animal model of infected wounds. *J Med Microbiol.* 2011; 60:75-83.

Citation: Mazandarani A, Goudarzi S, Jafarabadi M, Azimi Nekoo E. **Effects of Cold Plasma on *Staphylococcus Aureus*.** *J Family Reprod Health* 2022; 16(3): 212-6.